

Rutland 500 Windcharger

Owners Manual

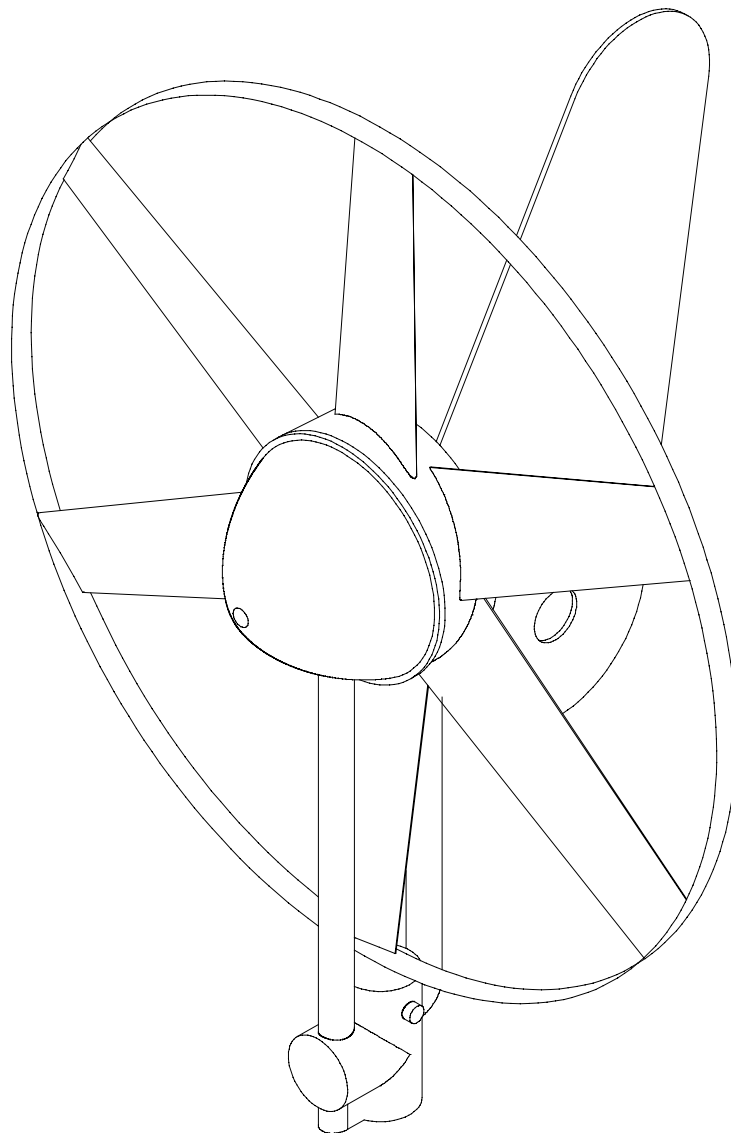

Contents

	Page
INTRODUCTION.....	2
CHECK YOU HAVE RECEIVED.....	3
WHAT YOU WILL NEED.....	3
SITING THE WINDCHARGER.....	4
General Considerations.....	4
On Board Systems.....	5
Land based Systems.....	6
ASSEMBLY & INSTALLATION.....	7
Tail Assembly.....	7
Fitting Generator to the Tower.....	8
Final Mechanical Check.....	8
BATTERIES.....	9
CABLE SPECIFICATION.....	10
ELECTRICAL CONNECTION.....	10
BASIC WIRING DIAGRAMS.....	11
UP AND RUNNING.....	12
SPECIFICATION AND PERFORMANCE.....	12
INSPECTION AND MAINTENANCE.....	13
TROUBLESHOOTING.....	14

INTRODUCTION

This manual contains important information concerning your Rutland 500 Windcharger and its installation and operation.

It is strongly recommended that you read this manual and familiarise yourself with its contents before installing and operating the Windcharger system.

The Rutland 500 Windcharger is designed to provide a direct current (DC) power supply via a battery bank for 12V equipment, lighting, etc. It is ideal for leisure applications which require battery charging on non-mains sites.

WARNING!

- *When turning, the Windcharger is capable of generating voltages in excess of the nominal voltage. Caution must be exercised at all times to avoid electric shock.*
- *No attempt to repair the system should be made until the wind generator is restrained from turning.*
- *The Windcharger is fitted with ceramic magnets which can be damaged by heavy handling. The main generator assembly should be treated with care during transit and assembly.*
- *It is essential to observe the correct polarity when connecting the Windcharger and all other components into an electrical circuit. Reverse connection will damage the Windcharger and incorrect installation will invalidate the warranty.*
- *The fuse supplied must be fitted to protect the system.*
- *If in doubt, refer to your dealer, a competent electrical engineer or the manufacturer.*

CHECK YOU HAVE RECEIVED

- 1 x fuse and fuse holder
- 1 x main generator assembly
- 2 x M8 x 12 Hex Head Bolts
- 1 x Tail Fin
- 1 x 2-way terminal block

In the event of loss or damage, consult your dealer or the manufacturer.

WHAT YOU WILL NEED

Tools

- Suitable wire stripper
- Small terminal screwdriver
- Large flat blade screwdriver
- 13mm spanner

Other Items You Will Need

- Mounting pole
- Cable
- Batteries
- Battery terminals
- Connector blocks (as determined by your total system)

Other Items You May Have Selected

- SR60 Regulator or RWS60 Charge Controller
- Inter-connect unit
- Cable kit
- Rutland 500 mounting kit
- Voltmeter & Ammeter

SITING THE WINDCHARGER

General Considerations

The location and height of the mounting pole or tower for your wind turbine will be the major factor in the overall performance of your system.

The smooth flow of wind over land and water is often interrupted by a multitude of obstructions causing wind shear and turbulence.

Wind shear describes the interference between the fast moving upper air and the slow moving air close to the ground and the resulting decrease in average wind speed as one gets closer to the ground.

Turbulence is caused by the wind passing over obstructions such as moored boats, trees and buildings. Both wind shear and turbulence diminish with height and can be overcome simply by putting the machine sufficiently high above them.

It is therefore essential that the wind generator should be located in an area as free as possible from disturbed wind flow. Bear in mind that downwind obstructions can be as detrimental to performance as upwind obstructions (Fig.1).

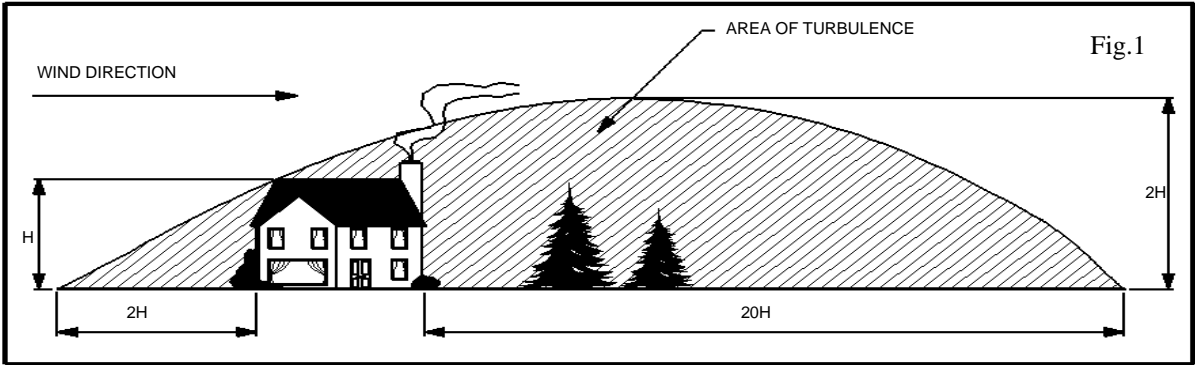

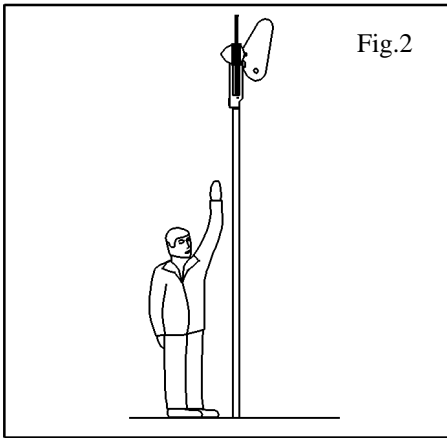

Fig.2

On Board Systems

The wind generator should be mounted in a safe position, a minimum of 2 metres (6.5 feet) above the deck and away from other obstacles which could interfere with the blades or tail assembly (Fig. 2).

The Rutland 500 Mounting Kit (PartNo.CA-12/01) is available for deck mounting.

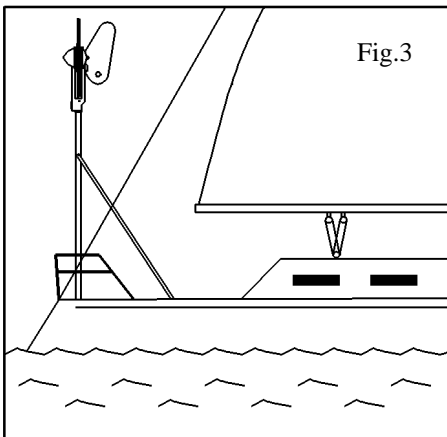

Fig.3

The Rutland 500 is designed to fit inside an aluminium tube with an internal diameter of 31.7mm (1¹/₄"').

Suitable tubes: Aluminium 1¹/₂" 10 SWG

We suggest the following mountings according to preference and site conditions:-

- Pushpit (Fig.3)

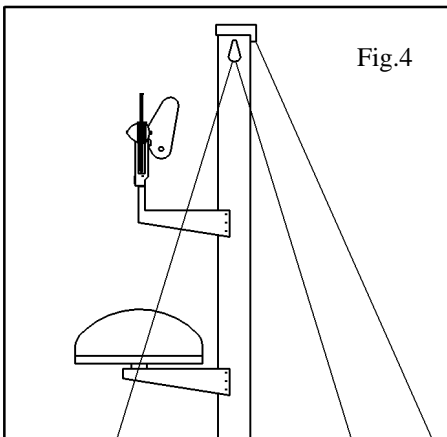

Fig.4

A suitable pole mounted to the deck with deck plates and guy ropes is the most popular method of mounting the Windcharger on yachts, eg. Rutland 500 Mounting Kit.

- Mizzen (Fig.4)

Mizzen mounting is suitable on larger yachts, taking advantage of greater wind flow the higher the wind turbine is mounted.

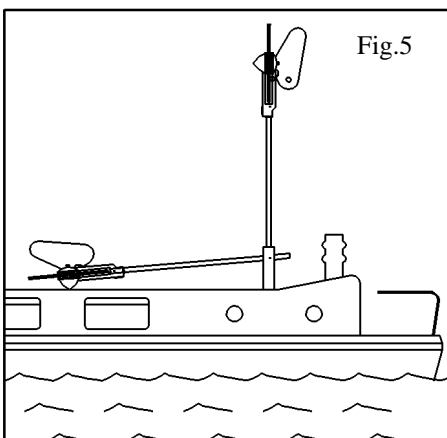
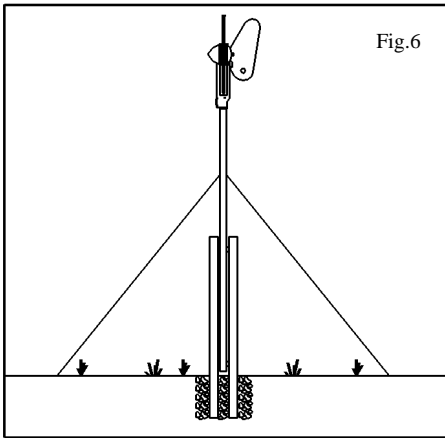

Fig.5

- River Boats (Fig.5)

A pivot pole is ideal for river boats as the Windcharger can easily be raised and lowered



Centre pivoted pole

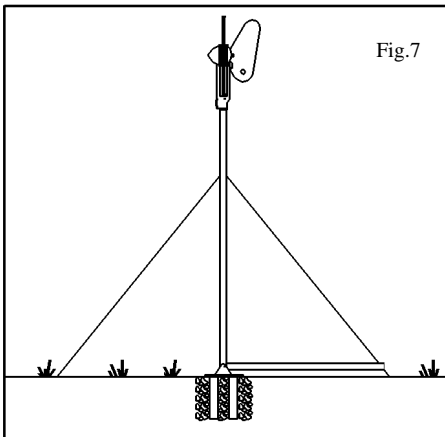

Base pivoted with gin pole

Land Based Systems

The Rutland 500 is designed to fit inside an aluminium tube with an internal diameter of 31.7mm (1¹/₄"").

A suitable mounting pole can be erected using a 6.5 metre (21 feet) Aluminium tube. The tube must be supported by a minimum of four guy lines.

The attachment points for the guy lines to the tower should be securely fixed to the tower.

- The guy wires should be a minimum of 3mm in diameter.
- The shackles should be a minimum of 5mm in diameter.
- Rigging screws should be a minimum of 5mm in diameter.
- All items should be galvanised or stainless steel for protection against corrosion.
- Where guy lines are looped, the loop must incorporate a thimble and be fitted with a minimum of three rope grips.
- All ground fixings must be made suitable according to the terrain.

We suggest pivot type towers as these allow for easier installation and lowering for access to the wind generator. Two forms of pivot tower are suggested in Figs 6 & 7.

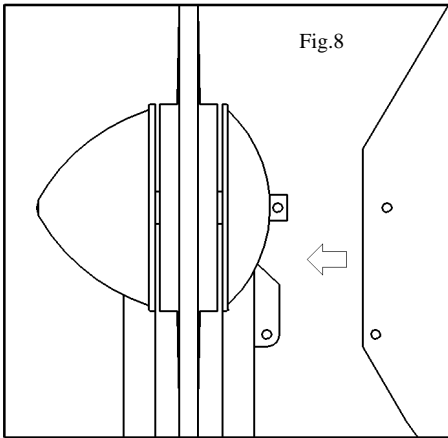

ASSEMBLY AND INSTALLATION OF THE WINDCHARGER

Tail Assembly (Fig.8)

1. Place the generator assembly on a flat soft surface, Nose Cone down.
2. Remove the 2 x M5 Pan head screws, washers and nut, one from the tail nut and the other from the support casting.
3. Slot the tail into position in the tail nut, ensuring the hole in the tail nut and the hole in the support casting align with the corresponding holes in the tail fin.
4. Replace the screws, washers and nut and secure in position.
5. Check tightness of all screws. (Do not over-tighten).

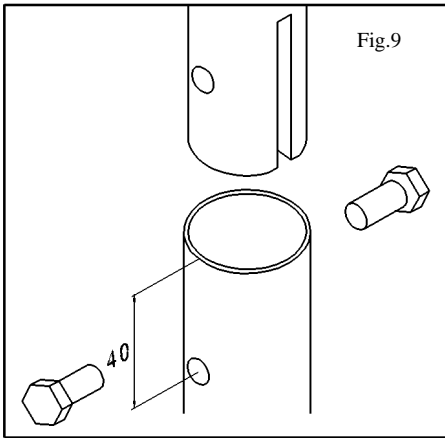

Fitting Generator to the Tower (Fig.9)

1. The post adapter fitted to the 500 is designed to fit inside a standard 31.7mm internal diameter tube
2. Mark and centre-punch two positions diametrically opposite, at 90° to the pipe seam if necessary, 40mm from top of the tube.
3. Drill two holes 8.5mm in diameter on centre-punch positions.
4. Position the Windcharger on the tower. Two M8 x 12mm screws and shakeproof washers are provided for securing once the cables are installed.

Note: When using the Rutland 500 Mounting Kit, items 2 and 3 can be ignored as the unit is pre-drilled.

Final Mechanical Check

1. Check the tightness of Tail screws.
2. Check the free rotation of the hub and yaw axis.

Do not raise the Windcharger at this stage, the turbine must be connected to the battery before the blades are allowed to turn in the wind.

BATTERIES

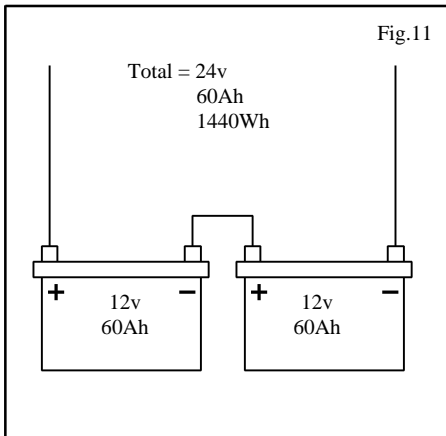
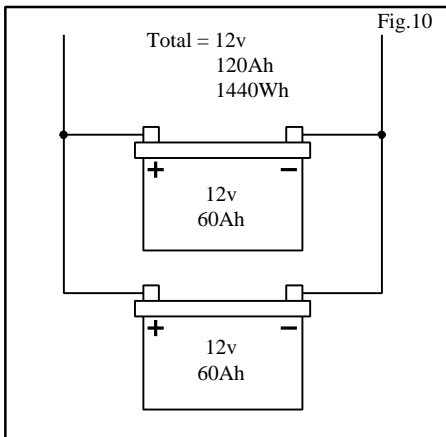

Leisure/Deep Cycle batteries are specifically designed for good performance in terms of charge/discharge cycles. Batteries are the most important part of your battery charging system and should be sized according to your load requirements and provide at least 3 days reserve capacity. This will reduce cycling, prolong the life of the battery and ensure system reliability during periods of low wind.

Permanent connections should always be made to the battery terminals. Never use crocodile clips or similar devices. Battery terminals should be well greased with petroleum jelly or similar.

We strongly recommend the SR60 or RWS60 is fitted to prevent battery overcharging in strong winds and is essential with gel/sealed batteries.

Batteries may be linked as follows:

- In parallel to increase amp hours (Fig.10).
- In series to increase voltage (Fig.11).

Red is + Positive
Black is - Negative

CABLE SPECIFICATION

Cable Run (m)	Cable Size (mm ²) <u>12 Volt</u>
0-20	2.5
21-30	4
31-45	6
46-80	10

Table.1

The cable used for connection of the Windcharger to the batteries should be in accordance with table 1. The use of a smaller cable than recommended will reduce the performance of the charging system.

Cable kits are available from your dealer or the manufacturer.

10m x 2.5mm² including battery clips
(CA-10/11)

20m x 2.5mm² including battery clips
(CA-10/12)

ELECTRICAL CONNECTION

1. Run the cable selected (see Table 1) down the inside of the pole.
2. Connect the wind generator flying leads to the cable using the connector block supplied, taking care to observe polarity.

Red is + Positive
Black is - Negative

Wrap the connection with insulation tape to secure/protect from environment. Alternatively join the cable using a latching-type plug and socket.

3. Reposition and secure the wind generator to the tower using the screws and shakeproof washers provided
4. Final Electrical Connection:

Select one of the following 2 basic systems and follow the manual provided with the SR60 or RWS60.

SR60 Regulator and Fuse

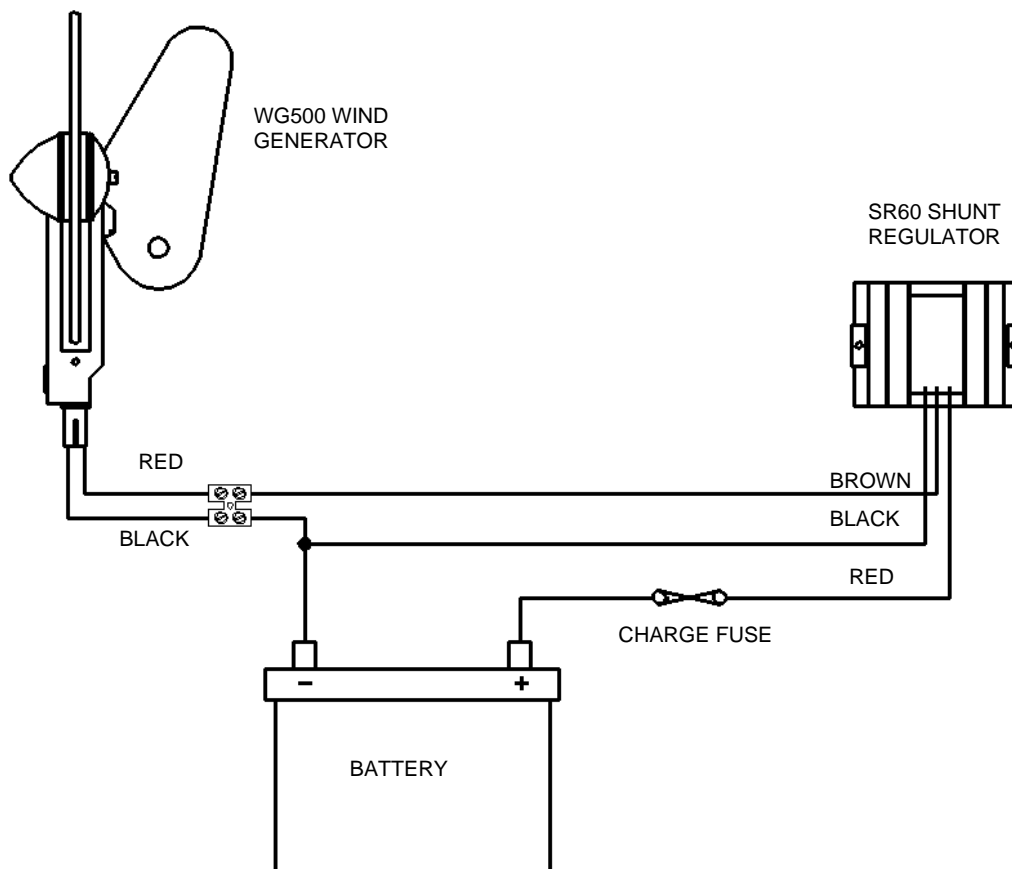

RWS60 Controller

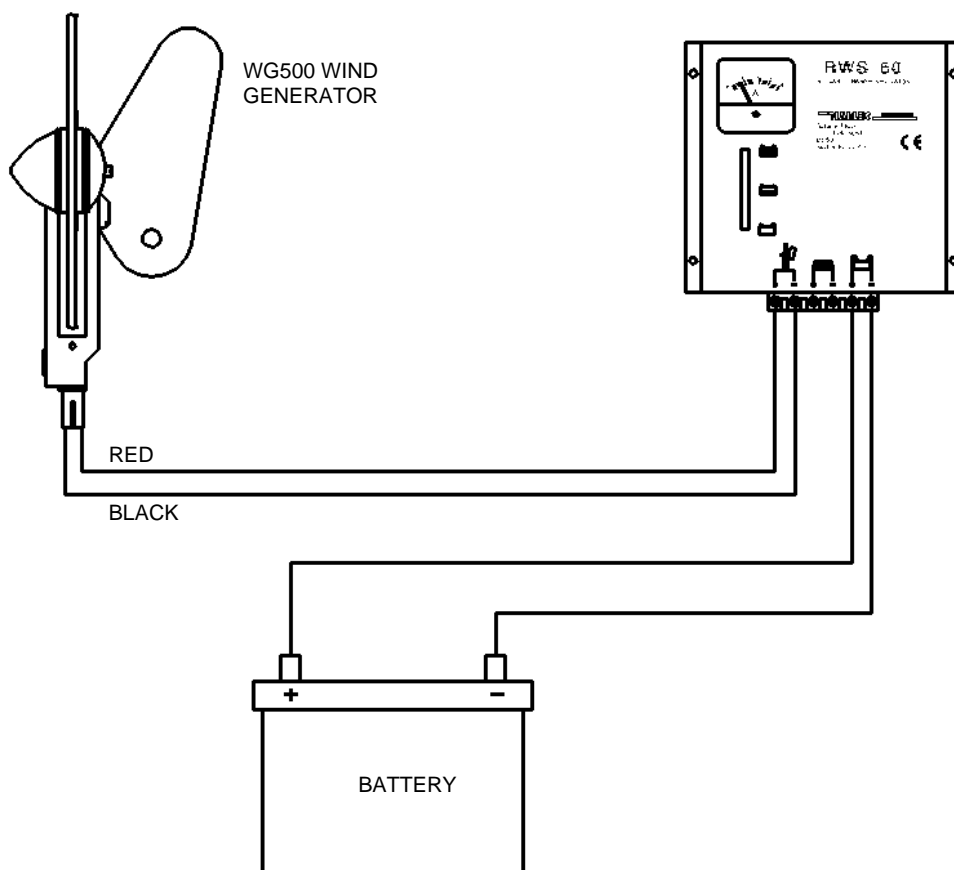

UP AND RUNNING

- Before raising and securing the wind generator, check that:
 1. All final mechanical checks have been made.
 2. The cable is not trapped.
 3. All electrical connections are secure and safe.
- The wind generator can now be raised into position.

Take care to avoid all moving parts when raising and lowering the wind generator.

- When raised, secure the structure firmly in an upright position. The performance of your Windcharger can be impaired if the pole is not vertical .

SPECIFICATION AND PERFORMANCE

Charge into 12v Battery (Amperes)

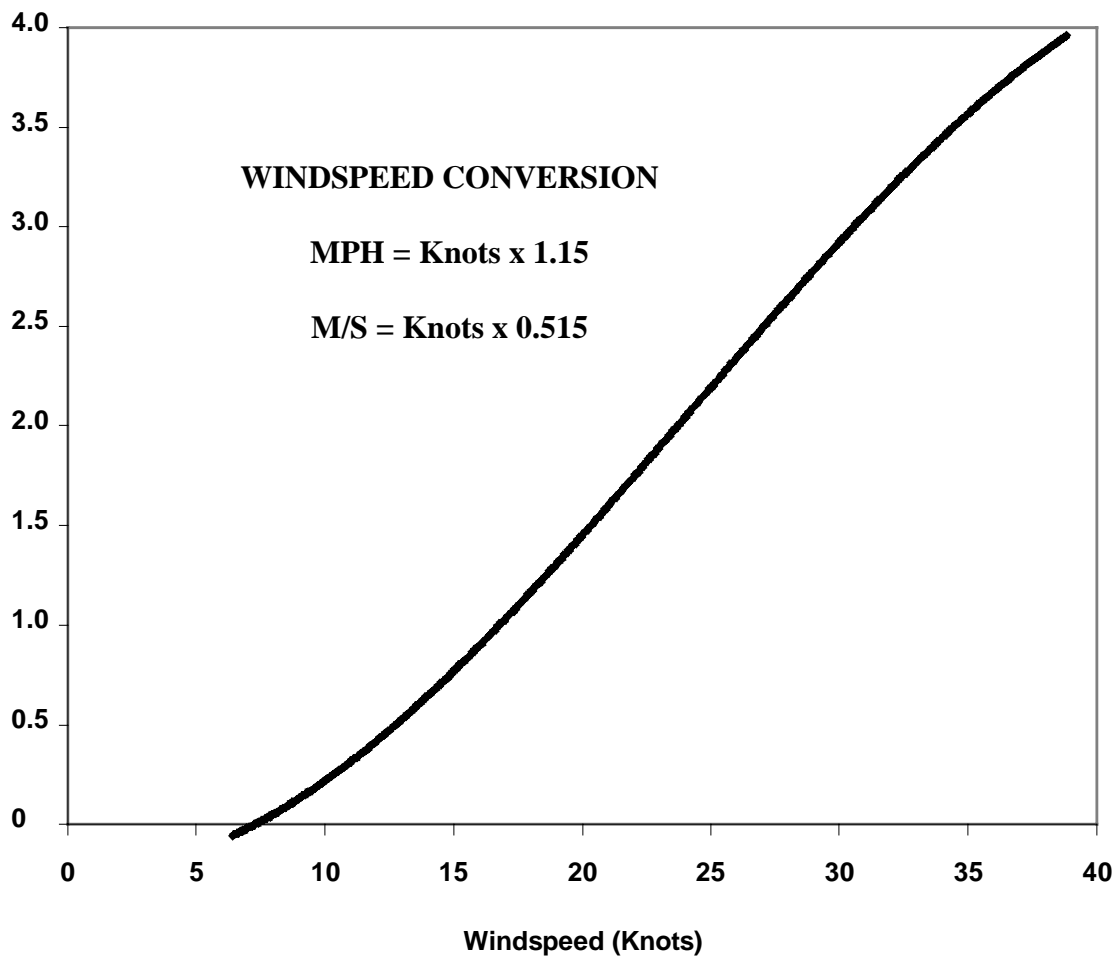

INSPECTION AND MAINTENANCE

The Rutland 500 requires no scheduled maintenance but an annual inspection should be carried out to monitor the general condition of the system.

- Before inspection, the turbine should either be lowered to the ground or tied to prevent the generator from turning. To stop the generator from turning proceed as follows:
 - 1) Turn the wind generator out of the wind (180°) using the tail. A hole is provided in the tail fin to assist in this. The generator will eventually slow down.
 - 2) Tie a blade to the mounting pole to prevent it from rotating.
- Whilst the generator is stationary, the following routine checks should be performed:
 - 1) Check all nuts, bolts and screws for tightness.
 - 2) Check the yaw axis for free rotation.
 - 3) Check tower assembly for condition.
 - 4) Check the tension of the guy wires if applicable. The tension of guy wires should be checked frequently during the first year.
 - 5) The unit can be wiped with a mild detergent and rinsed with water to remove dirt and debris.

TROUBLESHOOTING

In the unlikely event that your Rutland 500 should develop a defect, the turbine should either be lowered to the ground or tied to prevent the blades from turning before the following inspection is carried out.

1. Read the Electrical Connection (page 10) and Up and Running (page 12) and be satisfied that your system complies.
2. If your Rutland 500 fails to turn or produces low output, check the following:
 - **Is there sufficient wind?** The Rutland 500 needs 5 knots wind speed to start charging. The wind speed across the turbine blades may be greatly reduced in a marina or built-up area compared with the reading on a mast-head anemometer or weather reports.
 - **Is the battery in good condition?** Check the voltage and electrolyte level of each battery.
 - **Check electrical continuity** throughout the system, especially corrosion and poor connections in cable joins and connector blocks.
 - **Check the brushes and slipring for wear or damage.** To inspect the brushes, remove the round plastic cap on the front of the main casting. The brushes can be inspected by removing the caps from the brush holders & withdrawing the brushes. Damage to the brushes and reduced power indicate a possible reverse connection to the battery (see Page 10).
 - **Check hub for free rotation with generator disconnected from battery.** If the hub does not rotate freely, check for a possible short circuit in the wiring. If no wiring fault is found refer to your dealer or manufacturer.
 - **Remove the SR60/RWS60** from the charging circuit and connect the Windcharger direct to the battery via an ammeter. If no charge current is measured and there is sufficient wind, contact your dealer or manufacturer. If charge current is normal the battery is fully charged or regulator is faulty.

If in doubt, refer to your dealer or manufacturer.

Notes

Notes

LIMITED WARRANTY

The Marlec Engineering Company Limited Warranty provides free replacement cover for all defects in parts and workmanship for 12 months from the date of purchase. Marlec's obligation in this respect is limited to replacing parts which have been promptly reported to the seller as having been in his opinion defective and are so found by Marlec upon inspection.

Defective parts must be returned by prepaid post to Marlec Engineering Company Limited, Rutland House, Trevithick Road, Corby, Northamptonshire, NN17 5XY, England, or to an authorised Marlec agent.

This Warranty is void in the event of improper installation, owner neglect or natural disasters and does not extend to support posts, inverters or batteries.

No responsibility is assumed for incidental or consequential damage or loss, damage caused by the use of any unauthorised components.

No responsibility is assumed for non "furling" versions of the Rutland Windcharger (ie. the Standard and Marine generators) where Marlec or one of its authorised agents finds that a generator incorporating a furling device should have been used.

Serial Number :