

# Rutland FM910-3 Furlmatic Windcharger

*for free power wherever you want it!*



Rutland Windchargers are without doubt one of the most unique and versatile battery chargers in use throughout the world.

The Rutland FM910-3 combines the established Furlmatic robust mechanical design with our latest 3 phase generator technology to deliver better performance and greater reliability than ever before. Primarily designed for land based applications, the Rutland FM910-3 has been used worldwide to provide year round power generation.

## Technical Features and Benefits



A low energy remote power site where a grid connection would otherwise cost thousands of pounds

- Efficient power conversion
- Rutland Windchargers generate greater ampere hours in real wind conditions than turbines of equal and often larger diameter! This is because our unique high inertia alternator designs maintain momentum between gusts unlike other designs that stall and have to rebuild up speed. This Rutland “flywheel” action results in more free power generated into your battery.
- Rutland Windchargers are the lowest cost per watt of power generated owing to our many in-house manufacturing efficiencies and volume of production for our worldwide customers
- More ampere hours are generated because of the Rutlands’ low wind speeds start up (of just 2.6 m/s) so power is being generated in the most typical wind speeds as well as being powerful in the strong winds
- Automatic ‘furling’ tail fin directs turbine out of wind above 16 m/s for gale protection
- Our low friction 3 phase alternators give a smooth and silent output
- Computer designed efficient aerofoil blades. The fine profile blades have a positive one-way-only fit that have been tested to withstand a loading with a safety factor 10 times the turbine’s maximum rpm.
- EEC directive 89/336/EEC compliance ensures no radiated interference
- Automatic thermostat protection in prolonged gales
- Modern, durable materials for excellent reliability and product longevity, typically more than 10 years

**Part No:** CA-02/01 (12V)  
CA-02/02 (24V)

**Packed Dimensions:** 250x310x350mm  
315x120x1010mm

**Packed Weight:** 17 Kg

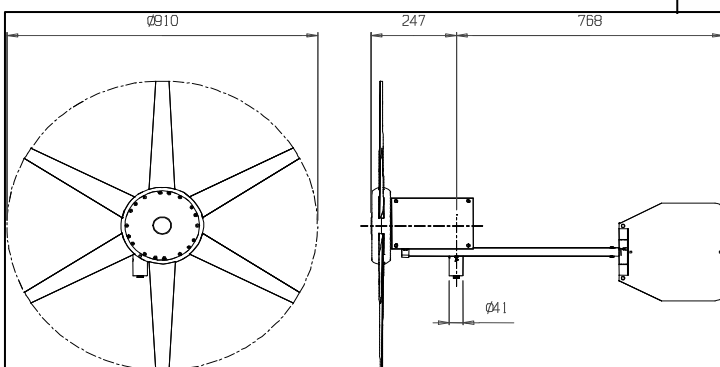
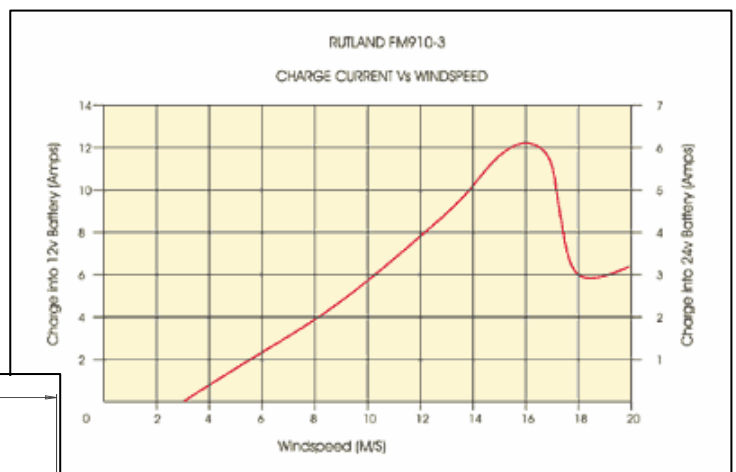

## Accessories for up and running

### MOUNTING POLE

Mounting pole for land based systems – the 910-3 can be installed on land using a 6m length of 48mm outside diameter tube with 41 mm internal diameter. The mounting pole can be fixed into the ground or on pivot type base. A minimum height of 6m and of 4 guy wires is recommended. More details are given in the installation manual. A Land Tower and Rigging kit is available from Marlec. The Land Tower kit comprises 3x tubes with joiners and a ground fixing spike giving an overall height of 6.4m. This must be supported by the Rigging Kit.

### VOLTAGE CONTROLLER

Choose from our two Pulse Width Modulation charge regulators. Both models progressively slow down the turbine when the batteries become full thus reducing long term wear and tear to the turbine.

#### HRSi Regulator

Single battery bank over voltage regulation with LED indicators for charging status and battery voltage.



#### HRDi Controller

Easy to use controller for charging up to 2 separate battery banks plus a solar panel input rated up to 160W. Full LED display reading charge currents and battery voltages.



Note that voltage regulators should always be sited within 1.5m of the battery to minimise voltage losses and ensure accuracy of battery regulation.

### BATTERIES

Deep cycle batteries should always be used for wind & solar charging. A good quality range of sealed AGM (absorbed glass matt) and gel batteries are available from Marlec.

### CABLE & CONNECTORS

Cable thicknesses are determined by the run of cable distance. For cable runs up to 20m/60ft 2.5mm<sup>2</sup> or 13AWG cable is recommended to maximise electrical efficiencies. Permanent battery connectors are recommended.

### SOLAR PANELS

Solar panels are a perfect complement to wind power, talk to Marlec about the BP Solar range of photovoltaic panels to give a seasonal balance of power to your system.

### INVERTERS

Inverters convert battery power to 230V for appliances such as laptops, TV's etc. Contact Marlec to discover the range available.



### Tried and Tested Applications:

- Telecommunications at isolated location
  - Remote broadband connections
  - Roadside safety signs (see picture)
  - Environmental monitoring e.g. water, air etc.
  - Land based navigation lighting and radio equipment
- ..... these and many other applications where grid power is unavailable.

Marlec Wind and Solar systems provide a **reliable, cost effective** and **environmentally sound** solution. Call us today to achieve the best technical solution for your power needs.

**Manufactured in the UK by:**

**Marlec Engineering Company Ltd.,**

**Rutland House, Trevithick Rd, Corby, Northants NN17 5XY**

**Tel: +44 (0)1536 201588 Fax: +44 (0)1536 400211 Email: [sales@marlec.co.uk](mailto:sales@marlec.co.uk)**

**Or visit our website: [www.marlec.co.uk](http://www.marlec.co.uk)**