

# Rutland 503 Windcharger Fault Finding Guide

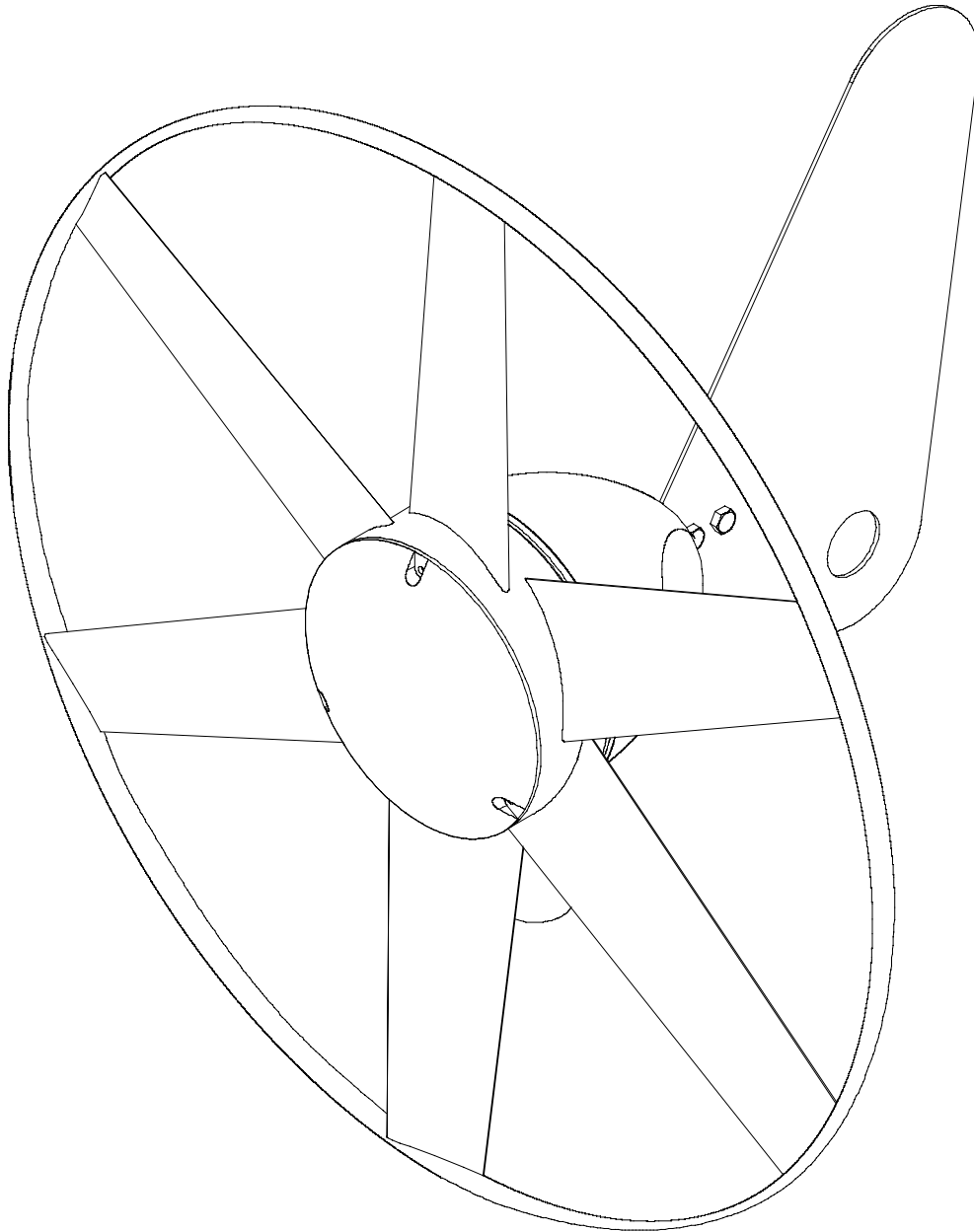



## INTRODUCTION

This manual contains important information concerning fault finding on your Rutland 503 Windcharger.

It is strongly recommended that you read this manual and familiarise yourself with its contents before attempting to repair the Windcharger system.

To use this fault finding guide, open out this flow chart, select the symptom in the left hand column & follow the arrows & instructions.

### **WARNING!**

- *When turning, the Windcharger is capable of generating voltages in excess of the nominal voltage. Caution must be exercised at all times to avoid electric shock.*
- *No attempt to repair the system should be made until the wind generator is restrained from turning.*
- *The Windcharger is fitted with ceramic magnets which can be damaged by heavy handling. The main generator assembly should be treated with care during transit and assembly.*
- *It is essential to observe the correct polarity when connecting the Windcharger and all other components into an electrical circuit. Reverse connection will damage the Windcharger and incorrect installation will invalidate the warranty.*
- *If in doubt, refer to your dealer, a competent electrical engineer or the manufacturer.*

**Notes:****1. Insufficient Wind / Turbulence**

Please see page 4 of the WG503 Owners Manual "Siting the Windcharger"- Document No SM-115 supplied with the WG503.

**2. Turbine Not Turning**

- A. Check for a short circuit in the system. Ensure there are no wires trapped or shorted to the supporting pole or other earth on the system. Ensure all wiring is connected correctly and securely.
- B. Check that the generator hub is running freely by rotating the hub by hand. If it does not, it could be due to a mechanical defect inside the hub. If the hub produces a rumbling sound, this could be due to faulty bearings which should be replaced.

**3. Check Brushes and Slipping**

- Remove the generator from it's mounting & place it face down on a suitable flat surface.
- Remove the 2 screws which secure the tail fin in place, remove the tail fin. Slide the nacelle from the protruding semi-circular casting to expose the rectifier assembly.
- Remove each brush holder cap in turn & withdraw the carbon brush. Check the brushes for signs of damage or overheating, overheating indicates that at some time the battery has been connected with reverse polarity.
- Replace brushes if necessary.
- Replace the brush holder caps tightly.

**4. Check Battery Condition.**

- Check that the battery voltage is correct for the system.
- Check the battery terminal voltage.
- Check electrolyte level if a non-sealed battery is fitted.

**5. Check Regulator.**

*This section applies to the SR60 regulator. If you have a RWS60 or other regulator, please refer to the regulator manual.*

Before attempting to bench test the regulator, disconnect it from the system & re-connect the wind generator directly to the battery, if the system now charges as expected this indicates that the regulator is at fault, if the symptoms are still unchanged then this indicates the fault is elsewhere.

In order to check the regulator it is necessary to use a variable d.c power supply together with a voltmeter and ammeter, if this equipment is not available the regulator must be returned to the manufacturer.

- Connect the Black lead of the SR60 to the negative of the power supply.
- Connect both the Brown and the Red leads of the SR60 to the positive of the power supply.

- Slowly increase the voltage of the power supply until 13.8v is reached, at this point the regulator will begin to draw current, a further increase of the power supply voltage will cause the Regulator to draw more current.
- The built in blocking diode can be checked using a multimeter set to Ohms range applied between the Red & Brown leads of the Regulator. Positive lead to Brown, negative lead to Red should show continuity. Positive lead to Red, negative lead to Brown should show no continuity.
- If the Regulator does not operate as above it should be returned to the manufacturer or replaced.

## 6. Check Rectifier.

- It is first necessary to remove the generator and it's nacelle cover as in Note 3.
- Un-solder the 3 stator output leads from the rectifier.
- Using a multimeter on Ohms range, the rectifier can be tested as follows.

Red lead to +ve brush holder, Black lead to each a.c terminal - No Continuity  
 Black lead to +ve brush holder, Red lead to each a.c terminal - Continuity  
 Red lead to -ve brush holder, Black lead to each a.c terminal - Continuity  
 Black lead to -ve brush holder, Red lead to each a.c terminal - No Continuity

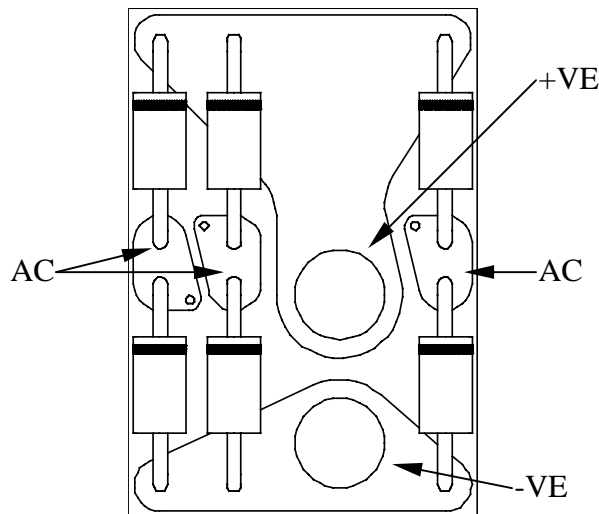

- If the rectifier does not check out as above it should be replaced.
- Re-solder the 3 stator output leads to the rectifier.

## 7. Check Winding.

- It is first necessary to remove the generator and it's nacelle cover as in Note 3.
- De-solder the 3 stator output leads from the rectifier.
- Using a multimeter on Ohms range or an Ohmmeter, measure the resistance between 2 of the 3 leads, the reading should be approx 1.8Ω at 20°C.
- Repeat the process for each combination of 2 leads, in each case the readings should be approximately the same.
- If the resistance measured is greatly different from above, the winding should be replaced.

## **8. Check System Wiring**

- Check all wiring & connections between the wind generator, regulator and battery for damage, corrosion & open circuit or poor/loose connections.

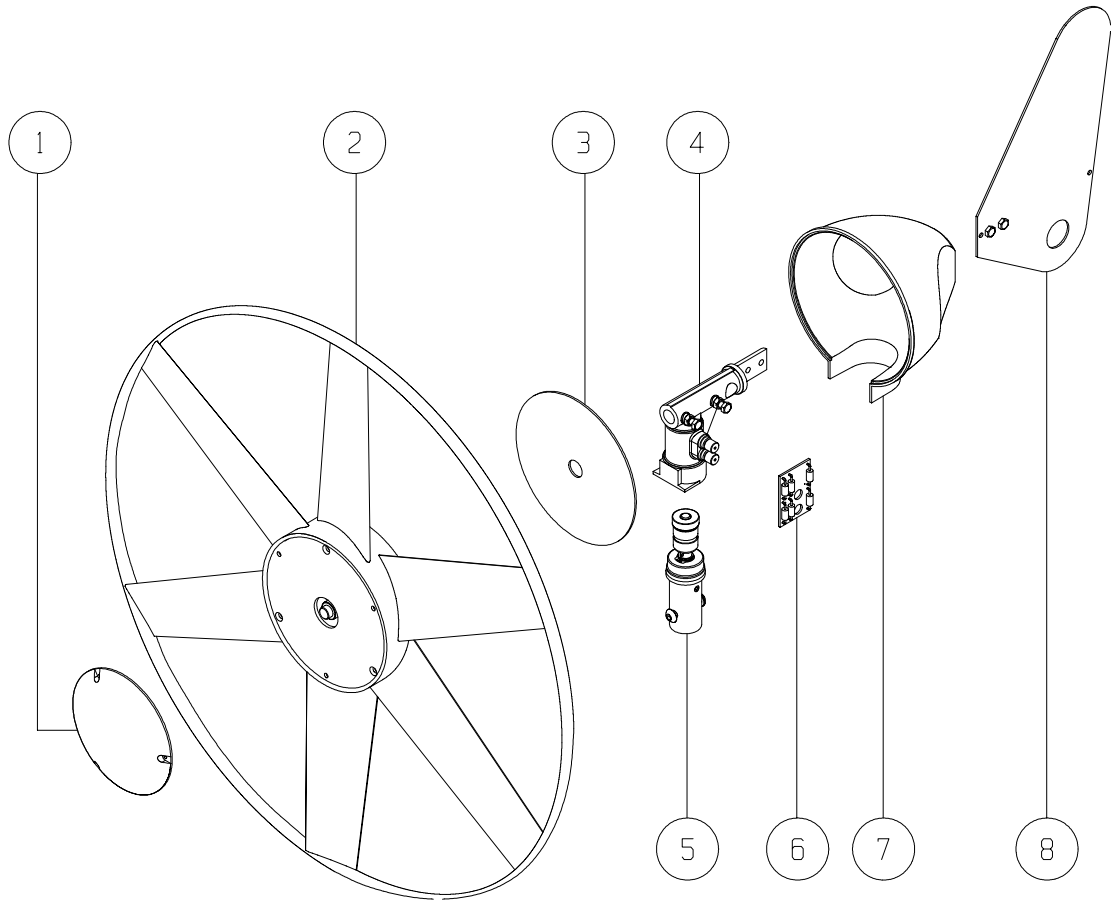

**Exploded View 1. Main assemblies.**

<b>Item No</b>	<b>Description</b>	<b>Marlec Part No</b>
1	Nose Dome	05-034
2	Hub assembly (Exploded view 2) <i>Including: Magnet assembly Qty 2 (Item 9) Turbine Blade (Item 10) Bearings Qty 2 (Item 11) Stator Winding (Item 12)</i>	SA-50/10
3	Nacelle Back Plate	05-035
4	Wind Shaft casting Assembly (Exploded view 3) <i>Including: Windshaft casting Brush Holder/Brush kit (item 13)</i>	SA-50/13
5	Post Adaptor assembly <i>Including: Post Adaptor Post Shaft Bearing (Item 15) Bearing (Item 16) Slipring (Item 17) Associated fasteners</i>	SA-50/14
6	Rectifier assembly	SA-50/16
7	Nacelle	05-031
8	Tail assembly	SA-50/15

**Items above with Part Nos prefixed ‘SA’ are supplied ready assembled.**

**Components of assemblies with Item numbers are available separately.**

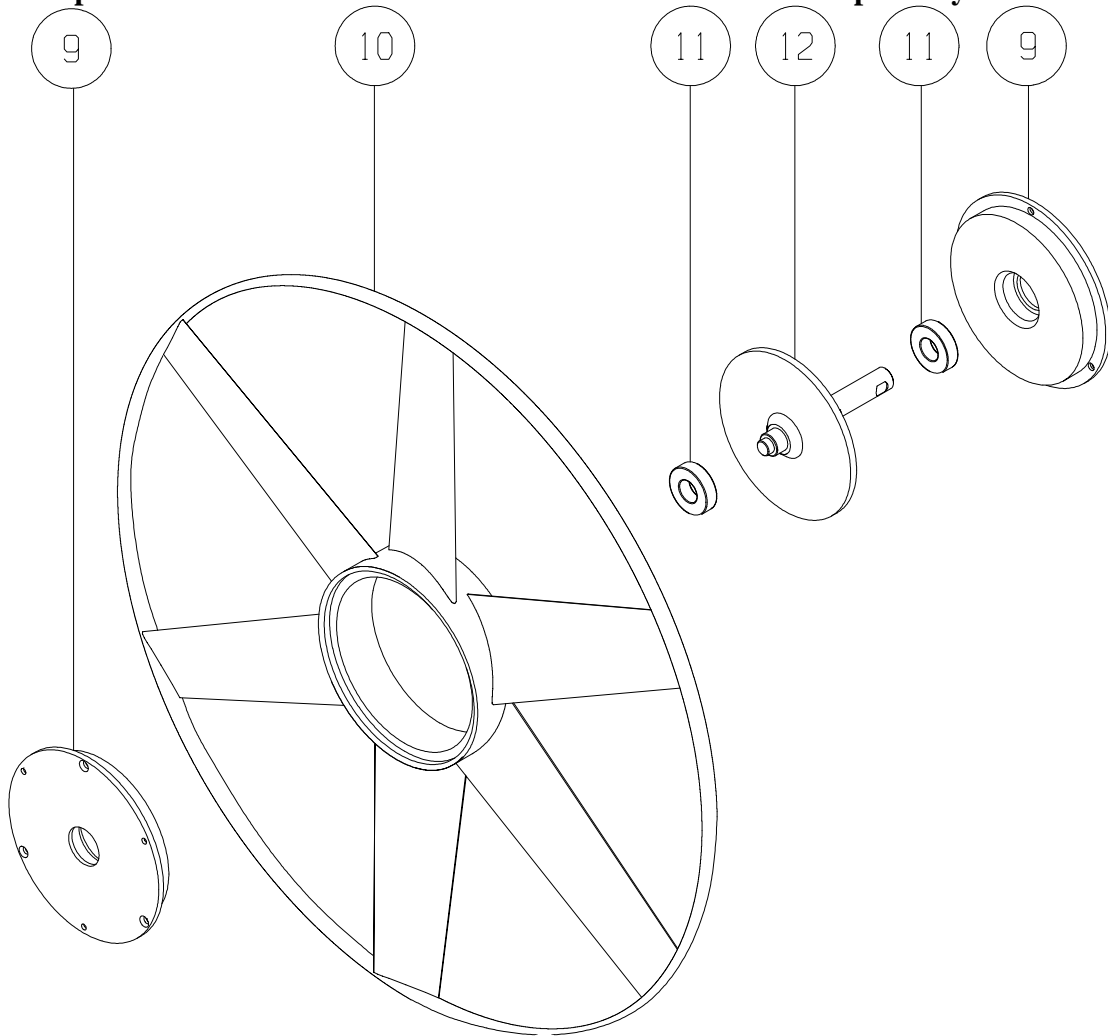

**Exploded view 2. Hub assembly**

<b>Item No</b>	<b>Description</b>	<b>Marlec Part No</b>
9	Magnet assembly (pair)	SA-50/12
10	Turbine Blade	05-001
11	6002ZZ bearing (2 per hub)	921-014
12	Stator winding (including bearings)	SA-50/11



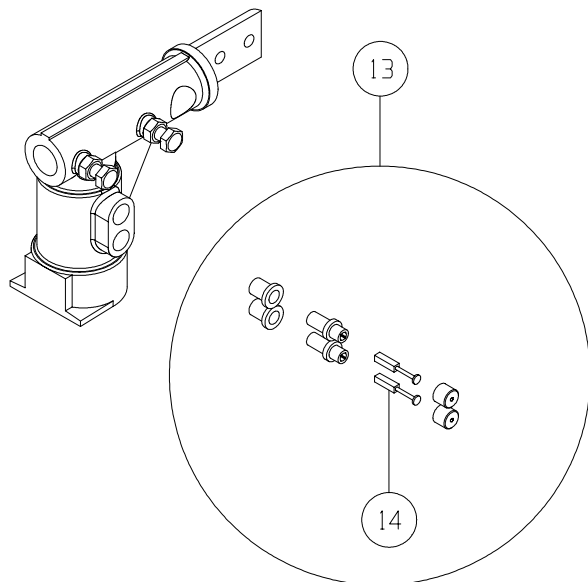

**Exploded view 3. Wind shaft casting assembly**

Item No	Description	Marlec Part No
13	Brush Holder/Brush Kit	SA-10/04
14	Brush 4x4x15 (2 per unit)	917-001

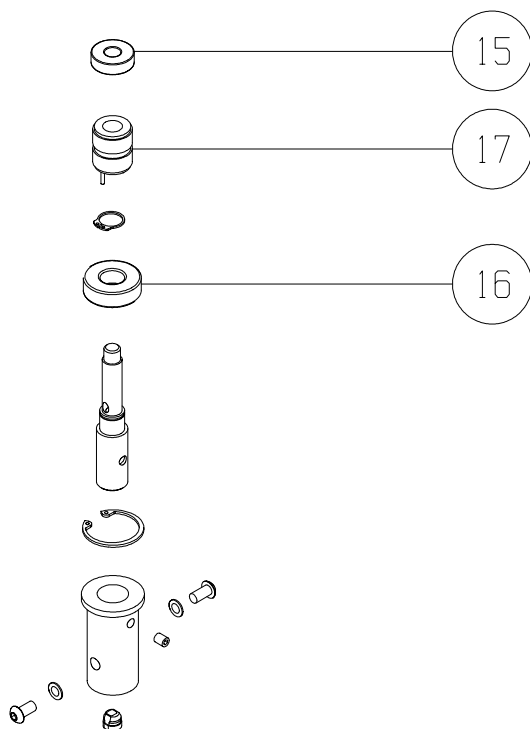

**Exploded view 4. Post adaptor assembly.**

Item No	Description	Marlec Part No
15	6000ZZ bearing	921-009
16	6202ZZ bearing	921-001
17	Slipring	919-001